

NOTE: THESE PRINTS ARE NOT FOR CONSTRUCTION.
DRAWINGS ARE FOR PRELIMINARY USE ONLY.

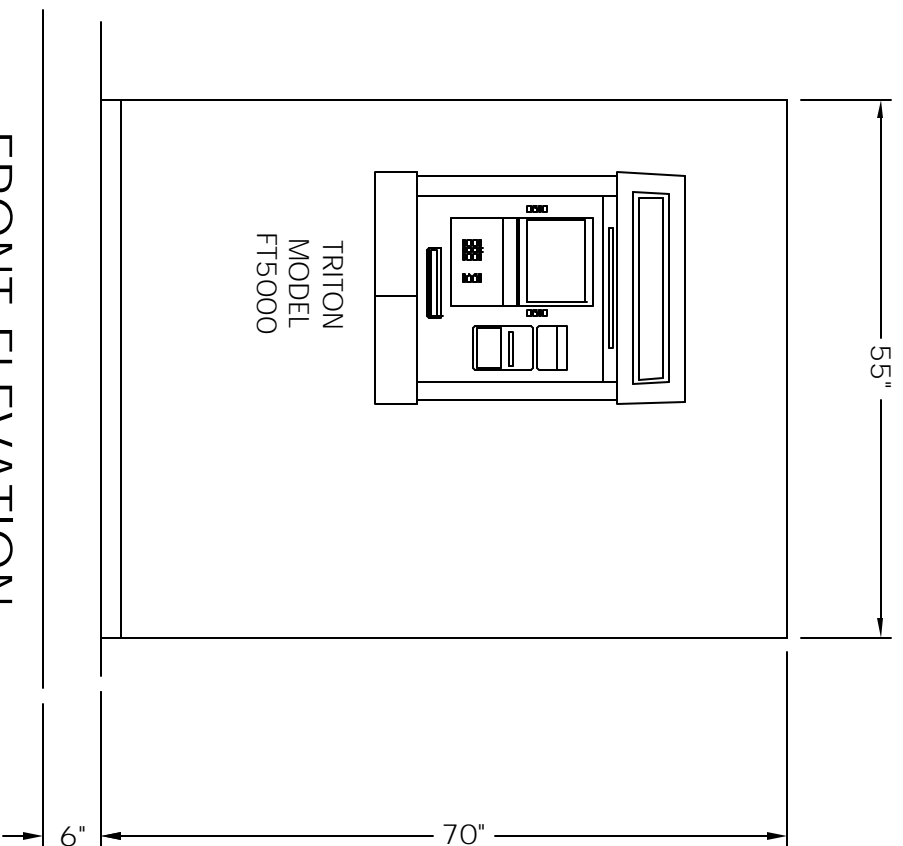

FRONT ELEVATION

SCALE: 1/2" = 1'

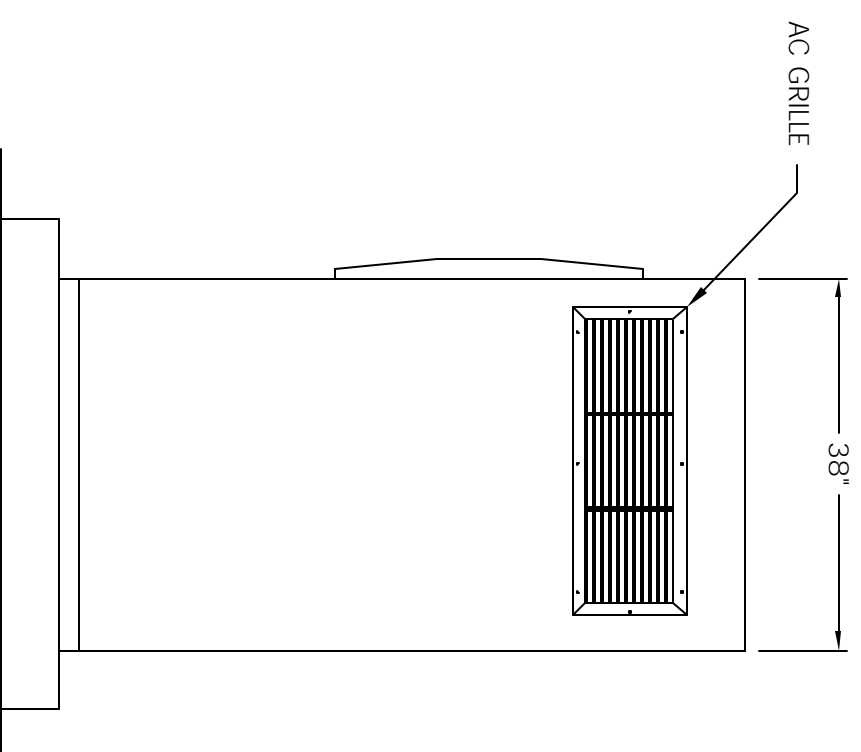

RIGHT ELEVATION

SCALE: 1/2" = 1'

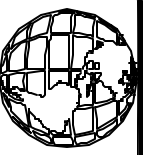

HERITAGE

The World Leader in ATM Kiosks

DEALER: ATM VENTURES
ADDRESS: 17020 SEVEN PINES DRIVE
SPRING, TX 77379

KIOSK MODEL#
926 V
ATM
TRITON FT5000

JOB# P-4274 DATE 5/23/05 DWN AH REV
DESIGNED FOR: 1ST UNITED BANK
ADDRESS:

PAGE#
1

NOTE: THESE PRINTS ARE NOT FOR CONSTRUCTION.
DRAWINGS ARE FOR PRELIMINARY USE ONLY.

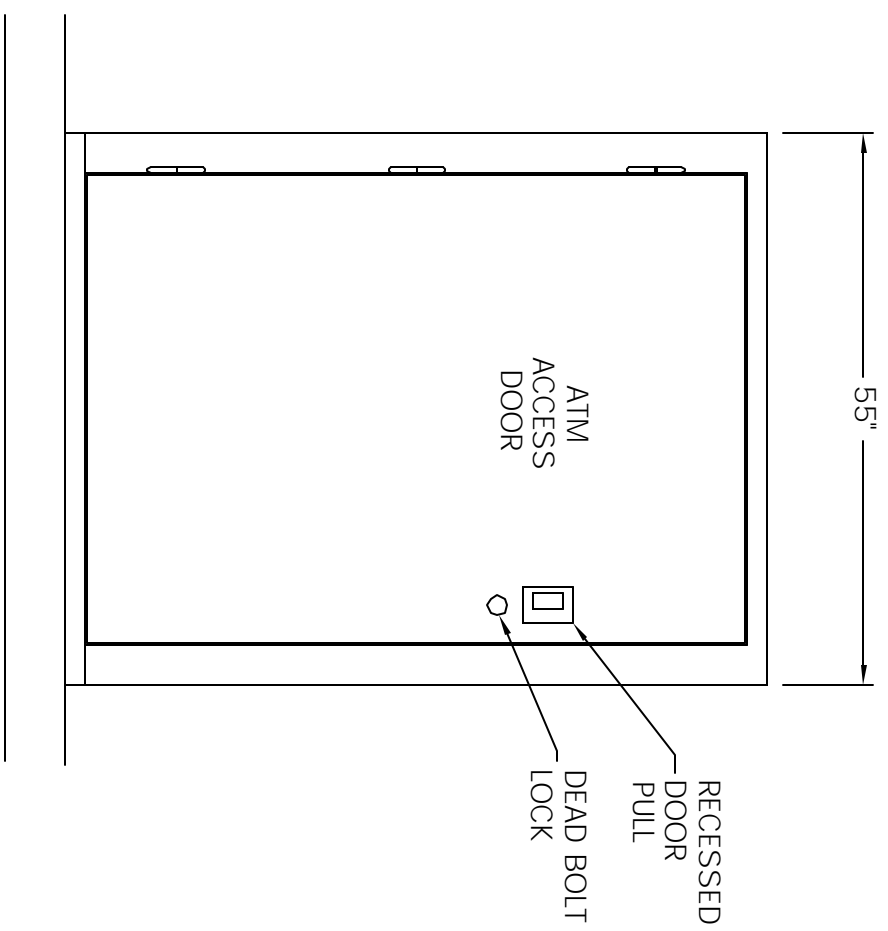

REAR ELEVATION

SCALE: 1/2" = 1'

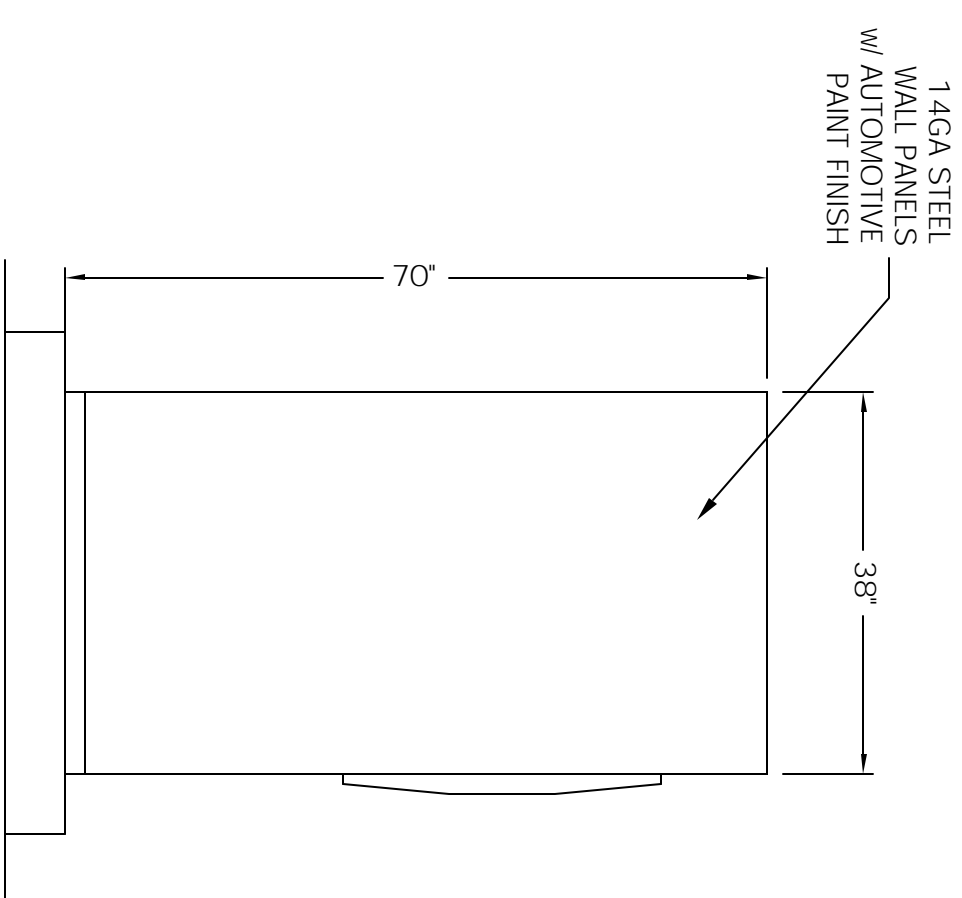

LEFT ELEVATION

SCALE: 1/2" = 1'

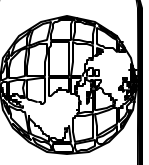

HERITAGE

The World Leader in ATM Kiosks

DEALER: ATM VENTURES
ADDRESS: 17020 SEVEN PINES DRIVE
SPRING, TX 77379

KIOSK MODEL#
926 V
ATM
TRITON FT5000

JOB# P-4274 DATE 5/23/05 DWN AH REV
DESIGNED FOR: 1ST UNITED BANK
ADDRESS:

NOTE: THESE PRINTS ARE NOT FOR CONSTRUCTION.
DRAWINGS ARE FOR PRELIMINARY USE ONLY.

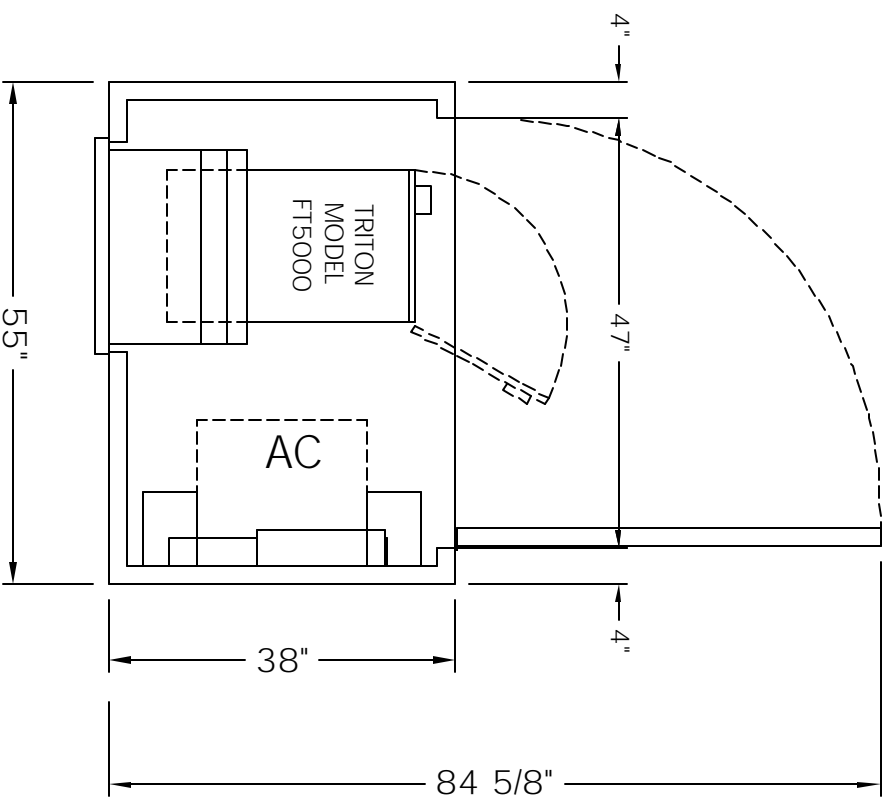

FLOOR PLAN W/ ATM IN SERVICE POSITION

ELECTRICAL NOTES:

HERITAGE INDUSTRIES HAS INSTALLED THE BUILDING ELECTRICAL SYSTEM TO THE ELECTRICAL PANEL. IT IS THE SITE CONTRACTORS' RESPONSIBILITY TO FURNISH AND INSTALL THE ELECTRICAL SERVICE AND METERING TO THE BUILDING, MAKING CONNECTIONS TO THE ELECTRICAL PANEL THROUGH THE PROVIDED RACEWAY. SITE CONTRACTOR IS RESPONSIBLE FOR BRINGING SERVICE TO THE BUILDING, AND PULLING ALL WIRES THROUGH THE PROVIDED RACEWAYS FOR PHONE, DATA AND SECURITY.

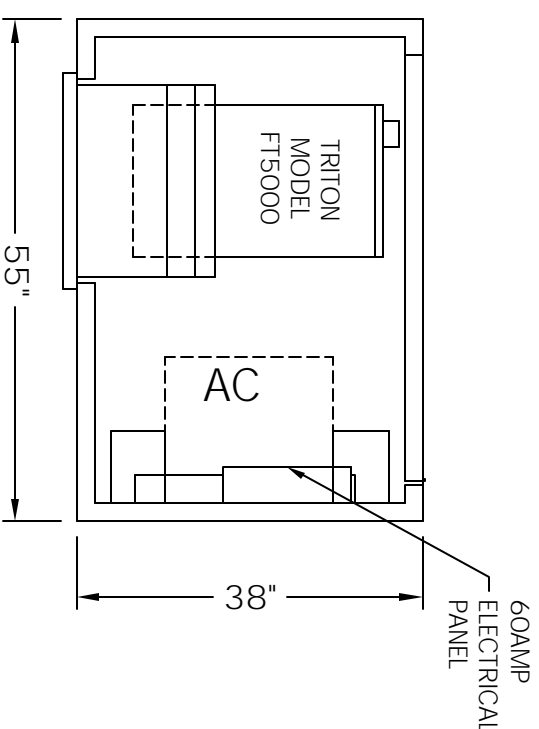

FLOOR PLAN W/ ATM IN USER POSITION

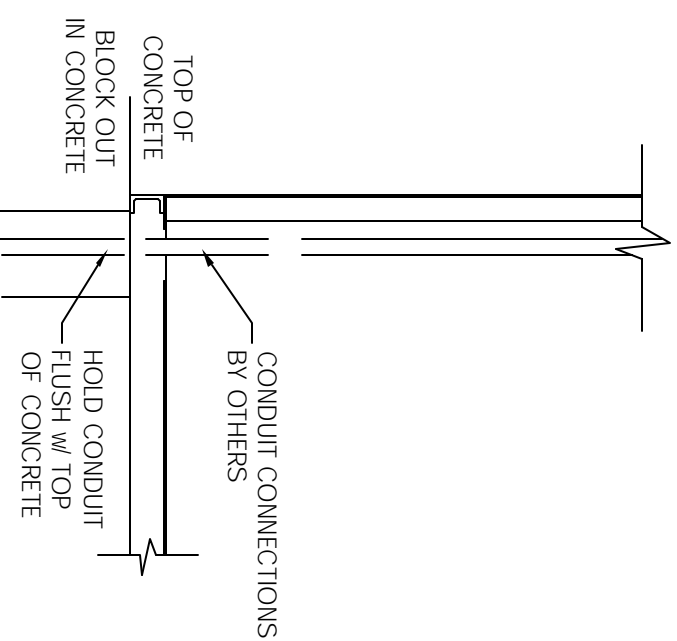

UTILITY CONNECTION DETAIL

Panel No.	Panel Description	Panel Size	Panel Location	Panel Capacity
1	MAIN	40	DP	20
3	MAIN	40	DP	20
5	ATM	20	20	---
7	GENERAL	20	20	---
9	SPACE	---	---	---
11	SPACE	---	---	---
2	A.C.	4	HEATER	20
4	HEATER	4	HEATER	20
6	SPACE	6	SPACE	---
8	SPACE	8	SPACE	---
10	SPACE	10	SPACE	---
12	SPACE	12	SPACE	---

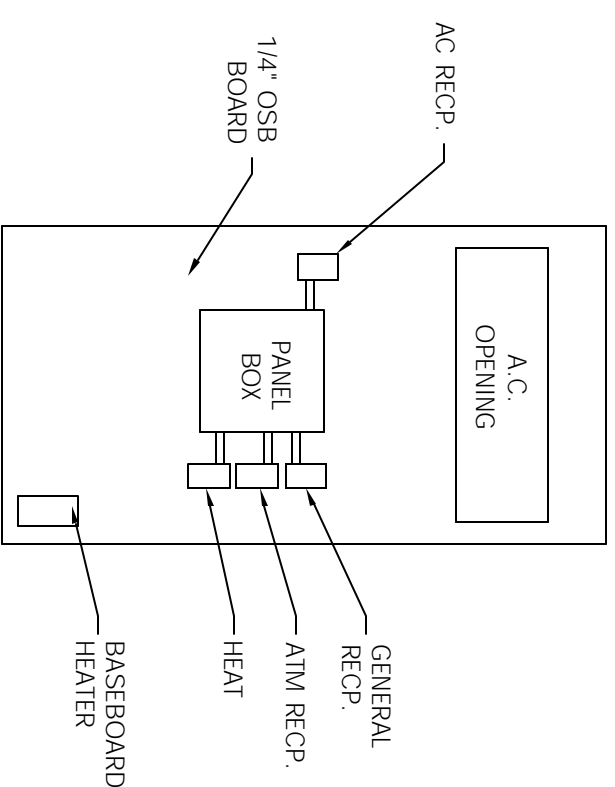

ELECTRIC WALL

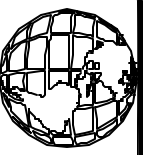

HERITAGE

The World Leader in ATM Kiosks

DEALER: ATM VENTURES
ADDRESS: 17020 SEVEN PINES DRIVE
SPRING, TX 77379

KIOSK MODEL# 926 V
ATM
TRITON FT5000

JOB# P-4274 DATE 5/23/05 DWN AH REV
DESIGNED FOR: 1ST UNITED BANK
ADDRESS:

PAGE# 3

